

iCP-440 Capacitor Bank Protection Relay

For Secure and Economical Bank Protection

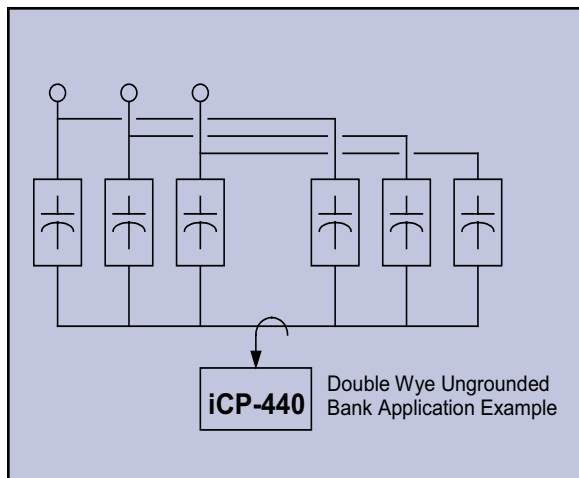

Your Solution for Shunt Capacitor or Filter Bank Protection and Control

The iCP-440 relay offers the advanced features you need to increase safety and reliability of capacitor banks. The iCP-440 relay monitors capacitor condition by checking the neutral quantity of single or double wye, grounded or ungrounded, fuseless or externally fused banks. It has intelligence to track self-canceling failures possible in double wye banks for optimal protection margins.

Exclusive Cooper features and functions, including the Idea Workbench™, Virtual Test Set™, and Relay Replay™ software functionality, provide the unprecedented ability to observe the relay's protection and control functions, while offering flexibility for custom applications.

Technically Advanced Capacitor Relay

- The iCP-440 relay detects capacitor bank unbalance when the compensated neutral quantity increases beyond a threshold. It reduces outage time by pinpointing the failed components within the bank. Because it is easily configured to permit the nulling of inherent bank unbalance, the relay provides maximum sensitivity for detecting internal problems.

Complete Capacitor Bank Protection

- Use the iCP-440 relay for protection and control of shunt capacitor or filter banks. It provides backup overcurrent and under- and overvoltage protection, voltage control and comprehensive metering up to the 15th harmonic. Cooper offers protective relays for a wide range of capacitor bank applications including: voltage differential, neutral unbalance, impedance, and negative sequence.

Get the Right Solution to Improve Reliability

- The Edison® Idea™ family of relays offers inherent communications options that improve reliability. Cooper can provide protective relays for a wide range of applications including distribution feeders, transformers, transmission lines, and capacitor bank protection. Our experienced relay engineers are available to provide application support when you need it.



For more information, visit our Web site at www.cooperpower.com, contact your Cooper Power Systems sales engineer, or call 877-CPS-INFO.

Edison® is a registered trademark of Cooper Power Systems, Inc., or its affiliates. Idea™, Idea Workbench™, Virtual Test Set™ and Relay Replay™ are trademarks of Cooper Power Systems, Inc., or its affiliates.

©2007 Cooper Power Systems, Inc., or its affiliates.

COOPER Power Systems
Energy Automation Solutions

1045 Hickory Street
Pewaukee, WI 53072 USA
www.cooperpower.com

Bulletin B165-06051 • March 2007 • New Issue